

# INDUSTRIAL CABINETS

Complex solutions for all industrial applications

**CONTEG**

# WE ARE CONTEG

## Leading Producer of IT, Data Center, and Industrial Solutions

We provide a global sales and technical support, have manufacturing plants in Europe—Czech republic equipped with latest technologies that meet all of the requirements for application in even the most demanding industrial environments.

CONTEG offers a comprehensive range of industrial cabinets and complex solutions for types of industrial operations including cooling, heating, ventilation and monitoring systems.

We are flexible and ready to supply with specific solutions according to customers requirements.



### Complex solution

cabinets, cooling, heating, ventilation, environmental monitoring



### User friendly

adapted for flexible and easy installation of all components inside the cabinet



### Comprehensive portfolio

free standing, wall-mount, steel/stainless steel



### Rigid, resistant

quality materials, single wall, up to IP 66



### Variable

for all types of applications and installations, including in-row installation



### Customized solutions

specific solutions according to customer's requirements



FSE



FSM



FSM-X



WME



WME-X

	FSE	FSM	FSM-X	WME	WME-X
Application	indoor installation	indoor installation	indoor installation outdoor installation food and chemical industry	indoor installation	indoor installation outdoor installation food and chemical industry
Material	sheet steel	sheet steel	stainless steel 1.4301 (AISI 304) stainless steel 1.4404 (AISI 316L)	sheet steel	stainless steel 1.4301 (AISI 304) stainless steel 1.4404 (AISI 316L)
Version	single-door double-door	single-door double-door	single-door	single-door double-door	single-door double-door
IP rating	IP55	IP55	IP55	IP66 IP55	IP66 IP55
Mechanical durability	IK10	IK10	IK10	IK10	IK10
Color	RAL 7035	RAL 7035	–	RAL 7035	–
Surface finish	epoxipolyester powder coating	epoxipolyester powder coating	fine ground surface	epoxipolyester powder coating	fine ground surface

# Cooling, Heating & Environmental Monitoring

We calculate the required cooling/heating power to maintain stable thermal comfort for the installed elements inside the cabinets and we then recommend you the appropriate sort of cooling

## Cooling Units

- Cooling capacity from 0.32 to 4 kW
- IP rating: IP54
- Operating temperature range from +10 °C up to +55 °C
- Certification: CE, cURus, cULus

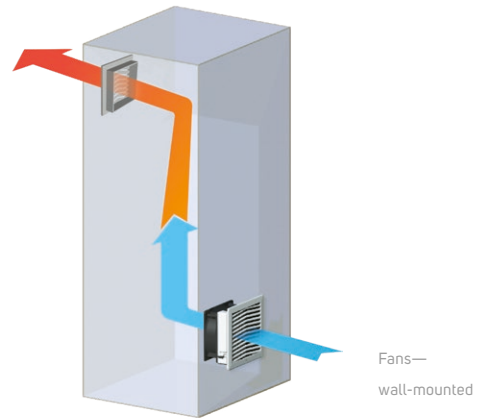

## Thermoelectric Coolers

- Cooling capacity from 0.1 to 0.8 kW
- IP rating: IP66
- Operating temperature range from -20 °C up to +65 °C

## Filter Fans

- Airflow from 12 up to 800 m<sup>3</sup>/h
- IP rating: IP54
- Operating temperature range from -10 °C up to +70 °C

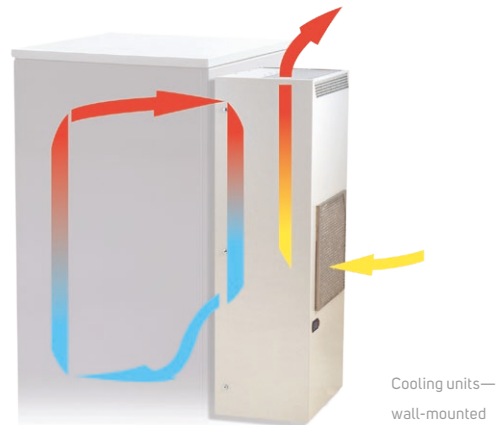

## Heaters

- Thermal output from 0.25 to 0.8 kW
- IP rating: IP20
- Operating temperature range from -10 °C up to +50 °C

## Environmental Monitoring

- Monitoring system RAMOS Plus comes in two versions: the standard variant and the GSM variant with a built-in GSM modem and an external antenna
- 4 intelligent ports, adjustable as input or output
- Communication: LAN: SNMP v1, v2 and v3; Modbus TCP, GSM: GSM version only
- E-mails or SNMP traps notifications

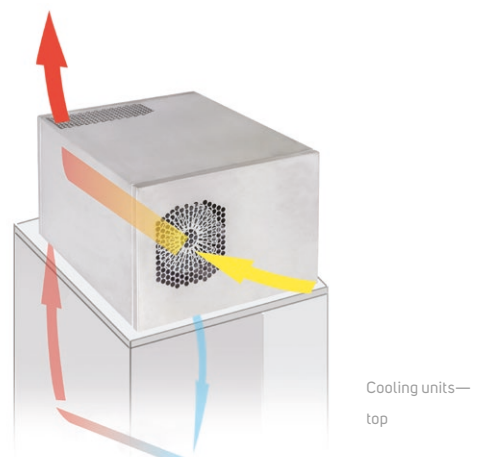



# FSE

## Free-standing Cabinets

Suitable for indoor, in-row assembly, demanding industrial environments  
Sheet steel, special cold-rolled profile, powder coated, welded by laser

### Main advantages

- UL certification
- **Load capacity up 1500 kg**
- Maximum use of interior space—possibility of placing the mounting plate between the rear posts
- Rigidity—welded frame construction made of special cold-rolled profile—powder coated
- **46 sizes:** from 1800 × 400 × 500 mm up to 2 200 × 1 200 × 800 mm
- Wide assortment of accessories

Cooling

filter fans, cooling units

Heating

heating unit

Monitoring

RAMOS Plus

Modifications

Tailor-made customer solutions—cut-outs according to your requirements before and after final surface finishing accessories

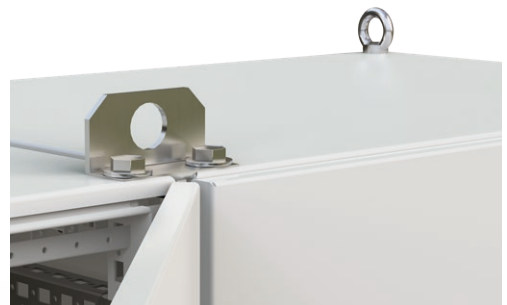



# FSM, FSM-X

## Free-standing Cabinets

### FSM

Suitable for indoor, demanding industrial environments

Sheet steel with side panels integrated in the frame (compact)

### FSM-X

Suitable for indoor and outdoor, the most demanding industrial environments, with an emphasis on a high level of cleanness and resistance to the surrounding environment (food, chemical industry)

Stainless steel, side panels integrated in the frame (compact)

## Main advantages

- Welded compact construction with integrated side panels
- Can be installed without an additional supporting plinth
- **Maximum use of interior space**—possibility of placing the mounting plate between the rear posts
- **Load capacity up to 700 kg**
- High protection against dust and water, IP 55
- Single/double door cabinet designs
- Wide assortment of accessories
- **FSM 28 sizes:** from 1 400 × 600 × 300 mm up to 2 000 × 1 600 × 500 mm
- **FSM-X 17 sizes:** from 1 400 × 600 × 300 mm up to 2 000 × 1 000 × 400 mm
- For outdoor solution we also offer the model FSM-O, stainless steel, IP 55

#### Cooling

filter fans, cooling units

#### Heating

heating unit

#### Monitoring

RAMOS Plus

#### Modifications

Tailor-made customer solutions—cut-outs according to your requirements before and after final surface finishing accessories

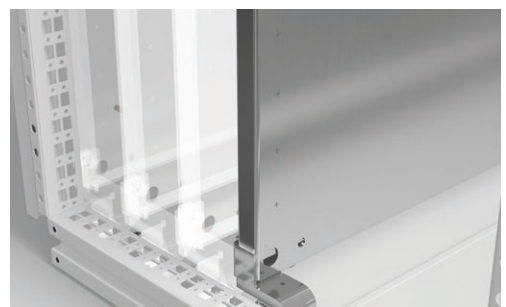
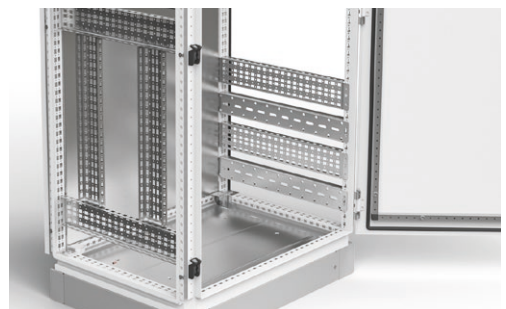



# WME, WME-X

## Wall and Pole-Mount Cabinets

### WME

Suitable for indoor  
Sheet steel, powder coated

### WME-X

Suitable for indoor and outdoor, the most demanding industrial environments, with an emphasis on a high level of cleanness and resistance to the surrounding environment (food, chemical industry)

Stainless steel

## Main advantages

- The doors are equipped with a polyurethane foam seal all around the perimeter
- **Rotary lock or three-point locking system**
- **Perforated mounting rails on side panels** (for cabinets 250 mm in depth and deeper)
- Mounting plate with a 50 × 50 mm marked raster
- **High protection against dust and water, IP 66, double door only IP55**
- Glazed door version—WME-G
- Wide assortment of accessories
- For outdoor usage we offer also version WME-O, stainless steel, highest protection, IP 66

#### Cooling

filter fans

#### Heating

heating unit

#### Monitoring

RAMOS Plus

#### Modifications

Tailor-made customer solutions—cut-outs according to your requirements before and after final surface finishing accessories

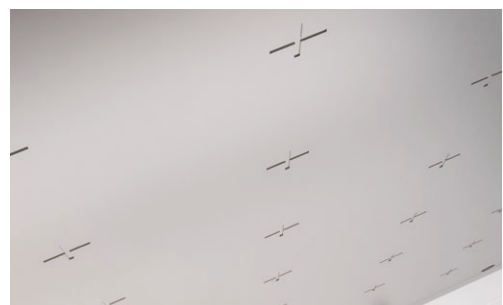

# ACCESSORIES

To create a variety of mounting surfaces and planes, we offer a wide range of system accessories designed for optimal use of the frame profile.

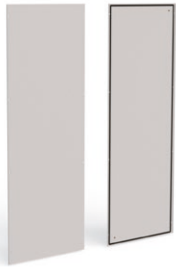

## Side panels

- FSE



## Plinths

- FSE, FSM, FSM-X

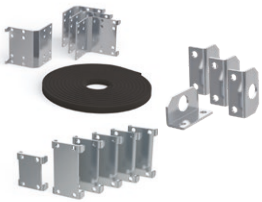

## Baying kits

- FSE



## Horizontal/vertical extrusions

- FSE, FSM, FSM-X, WME, WME-X



## 19" rails

- FSE, FSM, FSM-X, WME, WME-X



## Partial mounting plates

- FSE, FSM, FSM-X



## Cable fixing

- FSE, FSM, FSM-X, WME, WME-X



WE GROW  
TOGETHER

[www.conteg.com](http://www.conteg.com)

CONTEG

CONTEG, spol. s r.o.

Stetkova 1638/18

140 00 Prague 4

Czech Republic

Tel.: +420 565 300 358

[info@conteg.com](mailto:info@conteg.com)